

EMRAX

INNOVATIVE E-DRIVES

Motor Installation and Maintenance Manual

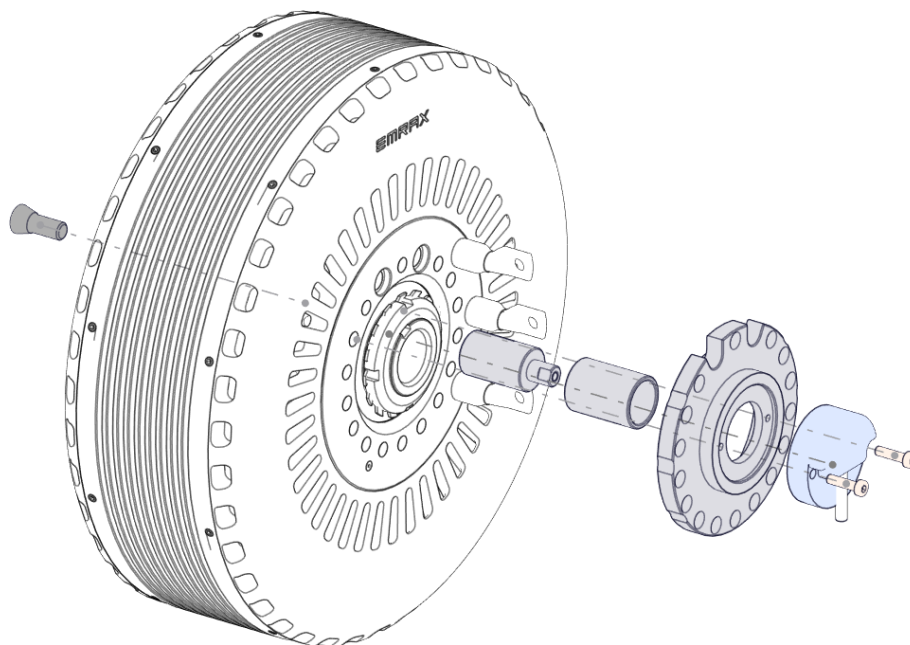

For additional information's turn to: support@emrax.com

All data found in this manual is subject to change without notice.

Notes:

Contents

1. General information	4
1.1. How to properly use this manual	4
1.2. Safe motor operation information	4
1.3. Intended use.....	5
1.4. Operating ceiling.....	5
1.5. Description of nameplate	5
1.6. Serial number	5
1.7. Delivery.....	5
1.8. Storage.....	5
1.9. Handling.....	6
2. Sensor mounting.....	7
2.1. RLS RM44 encoder installation.....	7
2.2. TAMAGAWA resolver installation.....	8
3. Motor installation.....	11
3.1. General space requirements	11
3.2. Mounting the motor.....	11
3.3. Motor output.....	12
3.4. Twin motor assembly	13
3.5. Motor cooling	14
3.6. Coolant fittings replacement.....	15
3.7. Temperature and sensor connection	15
3.8. Power supply and connections.....	16
4. Steps prior to starting.....	17
4.1. Steps prior to starting.....	17
4.2. Initial start.....	17
5. Maintenance	17
5.1. General	17
5.2. General cleanliness.....	17
5.3. Vacuum and compressed air cleaning.....	17
5.4. Cleaning with water and detergent.....	17
5.5. Bearings	18
5.6. Failure	18
5.7. Repair.....	18
5.8. Warranty.....	18

1. General information

1.1. How to properly use this manual

This installation and maintenance manual has been written to assist the user with proper procedures when handling, installing, operating, and maintaining the equipment. All the safety warnings and instructions in this book must be followed to prevent injury to personnel.

This manual must be kept for future reference during installation, operation, and maintenance.

1.2. Safe motor operation information



WARNINGS: High voltage and rotating parts can cause serious or fatal injuries. Qualified personnel should perform installation, operation, and maintenance of electrical machinery. For equipment covered by this instruction book, it is important to observe safety precautions to protect personnel from possible injury. Be sure to keep the installation and maintenance information for future reference. All warning and cautions must be followed.

Installation

- Avoid contact with energized circuits and rotating parts.
- Avoid bypassing or rendering any inoperative safeguards or protective devices.
- Avoid use of automatic-reset thermal protection where unexpected starting of equipment might be hazardous to personnel.
- Avoid contact with capacitors until safe discharge procedures have been followed.
- Be sure the motor shaft key is captive before the motor is energized.
- Avoid long exposure near machinery with high noise levels.
- When the motor is coupled to equipment, ensure that system vibrations are within acceptable limits (per ISO 10816-1) to avoid failure of the motor.
- Use proper protective gear, care, and procedures when handling, lifting, installing, operating, and maintaining the motor.
- If eyebolts are used for lifting motors, they must be securely tightened, and the direction of the lift must not exceed a 15° angle from the shank of the eyebolt.
- Do not use the motor shaft as a means for lifting.
- Do not lift both the motor and driven equipment with the motor lifting means.
- Do not stand on or place objects on the motor.

Maintenance

Safe maintenance practices performed by qualified personnel are imperative. Before starting maintenance procedures, be positive that:

- Equipment connected to the shaft will not cause mechanical rotation.
- Main motor windings and all accessory devices associated with the work area are disconnected from electrical power sources.
- The motor has been given time to cool.

Failure to properly ground the frame of the motor can cause serious injury to personnel. Grounding should be in accordance with National and local Standards and consistent with sound practice.

These instructions do not purport to cover all the details in motors nor to provide for every possible contingency to be met in connection with installation, operation, or maintenance. Should further information be desired, or should problems arise which are not covered sufficiently for the purchaser's purposes, the matter should be referred to EMRAX directly.

1.3. Intended use

Electrical motor will convert electrical energy into mechanical rotating energy or vice versa. Its primary usage is found in aviation, but not limited to. The motors can also be used for traction application, energy recuperation, ... If your intended use differs from standard applications seen on company website, please contact EMRAX support about its appropriate usage.

1.4. Operating ceiling

The electric motor can operate in ambient temperatures between -40 to +60°C. The maximum motor temperature allowed as recorded by internal temperature sensor is 120°C.

See motor technical tables for continuous and peak power ratings.

The maximum service ceiling is 6,500 m (21,300 ft).

1.5. Description of nameplate

Motor rating and identification data are furnished on labels and nameplates. Nameplates provide a permanent record of motor characteristics, plant identification and date of manufacture. Below is an example of a label that is attached to the shipping package:

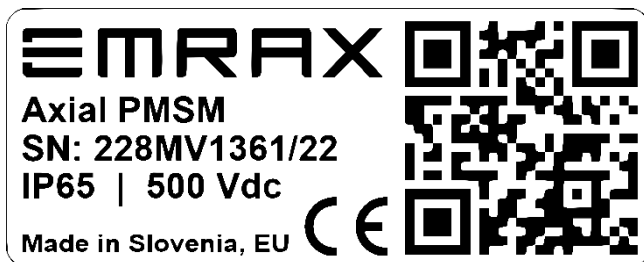

228 – Motor size
(188, 208, 228, 268, 348)

MV – Voltage version of the motor
(LV-low voltage, MV-medium voltage, HV-high voltage)

1361 – Serial number of the motor

22– Year of production (21-2021)

IP65– IP rating

500 Vdc – Maximum input voltage

1.6. Serial number

Every motor that is manufactured by EMRAX has a model and a serial number, which are permanently marked on the motor nameplate. When contacting EMRAX please provide the serial number and configuration of the motor.

1.7. Delivery

Prior to shipment, all motors are factory-tested and balanced. They are wrapped in protecting wrap and packed in boxes or bolted to a wooden base. Upon receipt, we recommend careful handling and a physical examination for damage which may have occurred during the transportation.

In the event of damage and to guaranty insurance coverage, notify the sales office or support email with picture evidence, without delay.

1.8. Storage

When motors are not immediately installed, they should be stored in their upright position in a dry, temperature-controlled place, free of dust, gasses, and corrosive atmospheres. Other objects should not be placed on or against them. Motors stored over long periods are subject to loss of insulation resistance and oxidation of the bearings.

Bearings deserve special attention during prolonged periods of storage. Depending on the length and conditions of storage it may be necessary to change rusted bearings. The weight of the rotor in an inactive motor tends to expel grease from between the bearing surfaces thereby removing the protective film that impedes metal-to-metal contact. As a preventive measure against the formation of corrosion by contact, motors should not be stored near machines which cause vibrations, and every 3 month their shafts should be rotated manually. Check the motor for smoothness of operation before first start, if necessary, contact EMRAX support.

Insulation resistance fluctuates widely with temperature and humidity variations and the cleanliness of components. When a motor is not immediately put into service it should be protected against moist, high temperatures and impurities, thus avoiding damage to insulation resistance. If the motor has been in storage more than six months or has been subjected to adverse moisture conditions, it is best to check the insulation resistance of the stator winding with an insulation tester.

If the resistance is lower than 1 Giga-ohm the windings should be dried in one of the two following ways:

- 1) Bake in oven at temperatures not exceeding 90 °C until insulation resistance becomes constant.
- 2) With rotor locked, apply low voltage, and gradually increase current through windings until temperature measured with thermometer reaches 90 °C. Do not exceed this temperature.

If the motor is stored for an extensive period, the rotor must be periodically rotated. In case the ambient conditions are very humid, periodical inspection is recommended during storage.

When storing the motor, please ensure that the motor is covered, so as not to permit any metal particles or dust to collect inside the motor. This is especially important when dealing with either the air (AC) or combined (CC) cooled motor.

1.9. **Handling**

Raising and moving of the motors should be steady and jointless, otherwise bearings may be harmed. Motor connectors, moving parts or cables, should not be used to lift the motor. The motor should be lifted by a sling around the rotor, or via an X-bracket attached to it. Take care, not to damage the sensors or connectors during manipulation.



When dealing with a motor, with a weight over 25 kg, please use lifting accessories (cranes, fork lifts,...).

In case of unbalanced loads (such as couplings or other attachments), additional slings or other effective means should be used to prevent tipping.

2. Sensor mounting

Depending on the application, a motor position sensor may be required. EMRAX offers a variety of different positioning sensors that can be supplied together with the motor. This chapter will cover their installation.

2.1. RLS RM44 encoder installation

Required parts:

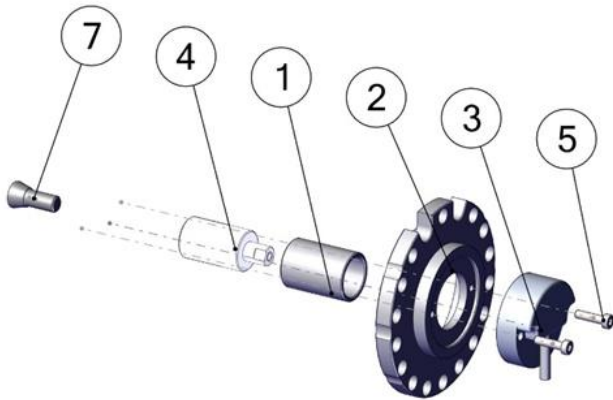

Figure 1: Required mounting parts

Description	Note	ID	Qty.
Adapter	268, 348 only	1	1
Encoder bracket	/	2	1
RLS RM44 encoder	/	3	1
Encoder magnet set	/	4	1
M4x16 bolt	/	5	2
Tapered bolt	/	7	1



Use an object with a flat face and make sure that the encoder magnet and the mounting face of the bracket are perfectly colinearly (in same line) aligned.

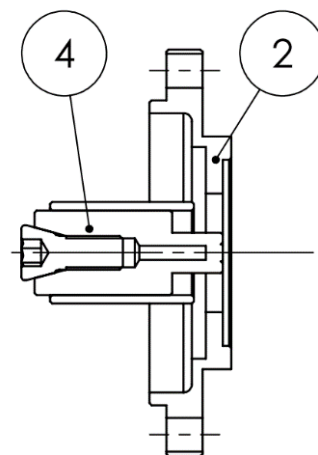

Figure 3: Magnet alignment

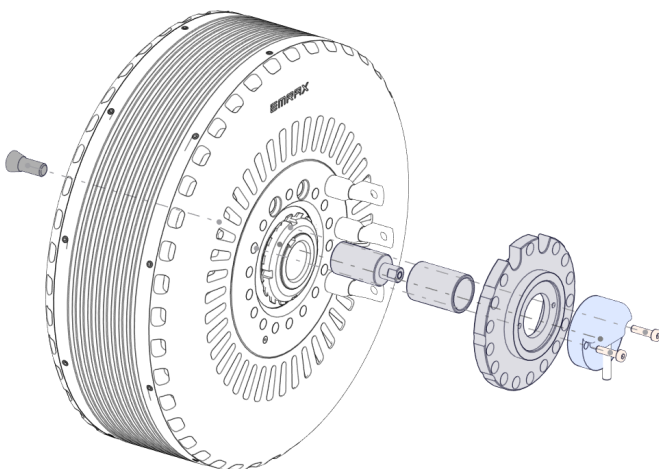

Figure 2: Encoder assembly

1. Place an adapter (1) inside the motor shaft (this step is only required for the 268 and 348 motor types). Before inserting the part use threadlocker glue on the faces, where the parts are mated.
2. Insert the tapered bolt (7) into the encoder magnet set (4) and lightly tighten it. Using threadlocker glue supplied with the kit on the threads is recommended.
3. Insert the encoder magnet set (4) into the backside of the motor (as shown on Figure 2), inside the motor shaft. Before inserting the part use threadlocker glue on the faces, where the parts are mated.
4. Mount the encoder bracket (2) on the back of the motor (as shown on Figure 2). Make sure that it is seated in its position, if necessary, use temporary bolts to tighten it to the motor (If the motor is liquid or combined cooled, please make sure that the coolant fittings are inserted, before mounting the encoder bracket, please refer to 3.5).
5. Align the encoder magnet set (4) to the sensor mounting flange of the encoder bracket (2).

6. Tighten the tapered bolt (7).
7. Mount the RLS RM44 encoder (3), to the mounting flange of the encoder bracket (2). Use the supplied M4x16 bolts (2), to mount the encoder. Using threadlocker glue on the threads is recommended.

Bolt size	Recommended Torque [Nm]	
	Dry	Lubed
Metric		
M4x0.7	4	3
M6x1	16	13
M8x1.25	40	32

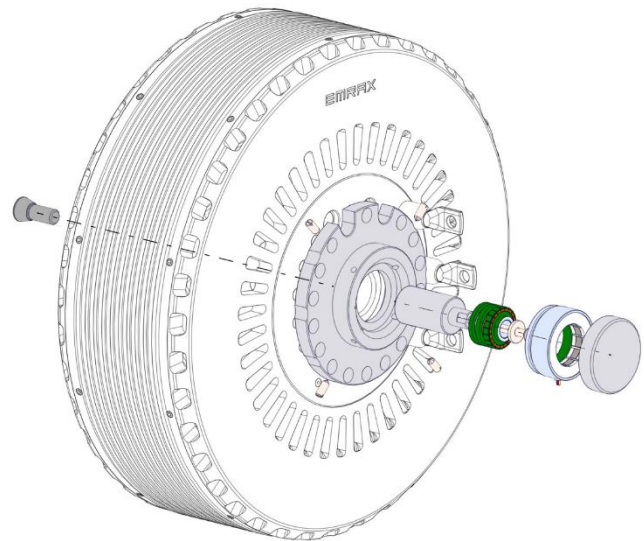

Figure 5: Resolver assembly

2.2. TAMAGAWA resolver installation

Required parts:

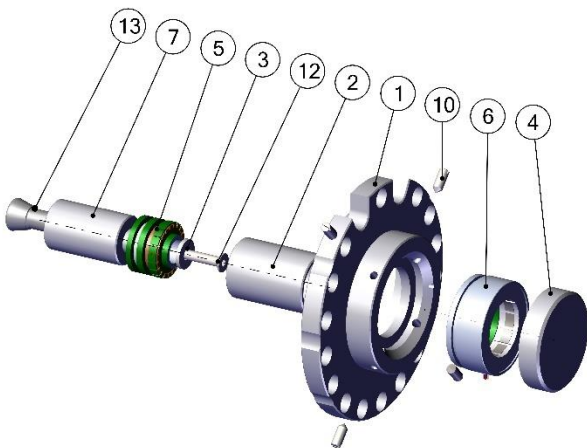

Figure 4: Required mounting parts

1. Place an adapter shaft (2) inside the motor shaft (this step is only required for the 268 and 348 motor types). Before inserting the part use threadlocker glue on the faces, where the parts are mated.
2. Assemble the rotor of the resolver. Start by applying threadlocker glue on the mating surfaces of the resolver rotor (5) and rotor holder (7) and pressing the parts together. Then insert the tapered bolt (13) into the rotor holder (5) and lightly tighten it. Using threadlocker glue supplied with the kit on the threads is recommended. Continue by screwing the resolver rotor (4) onto the rotor holder (7) by using the washer (3) and bolt (12) supplied with the kit.

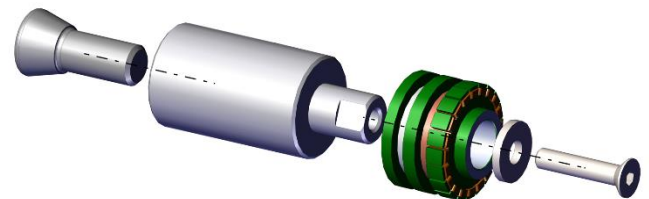

Figure 6: Rotor assembly

3. Insert the rotor assembly into the backside of the motor, inside the motor shaft (as shown on figure 5). Before inserting the part use threadlocker glue on the faces, where the parts are mated.

Description	Note	ID	Qty.
Resolver bracket	/	1	1
Adapter	268, 348 only	2	1
Washer	/	3	1
Resolver cover	/	4	1
Resolver rotor	/	5	1
Resolver stator	/	6	1
Rotor holder	/	7	1
DIN 914 set screw	/	10	4
M4x20 bolt	/	12	1
Tapered bolt	/	13	1

4. Mount the resolver bracket (1) on the back of the motor. Make sure that it is seated in its position, if necessary, use temporary bolts to tighten it to the motor. (If the motor is liquid or combined cooled, please make sure that the coolant fittings are inserted, before mounting the encoder bracket, please refer to 3.5).
5. Mount the resolver stator (6) to the mounting flange of the resolver bracket (1). While holding the resolver stator (6) down, use DIN 914 set screws (10) to bolt it down from the side. Using threadlocker glue supplied with the kit on the threads is recommended.
6. Make sure that the resolver stator and rotor teeth are aligned as on the picture below.

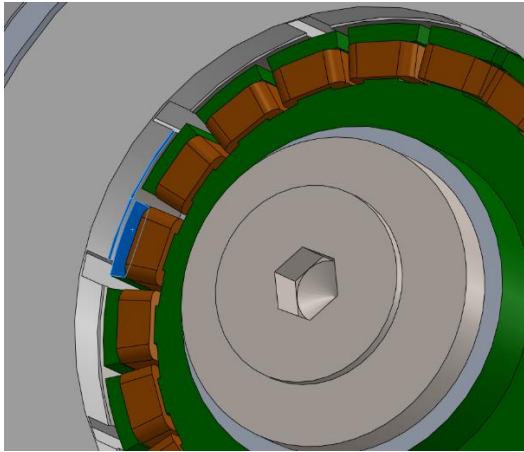

Figure 7: Tooth alignment

7. Tighten the tapered sensor bolt (13).
8. Mount the resolver cover (4) on the back of the resolver stator (6). Tap it gently with a hammer until it is firmly seated in place.

Bolt size	Recommended Torque [Nm]	
	Dry	Lubed
Metric		
M4x0.7	4	3
M6x1	16	13
M8x1.25	40	32

2.3. TAMAGAWA tandem resolver installation

Required parts:

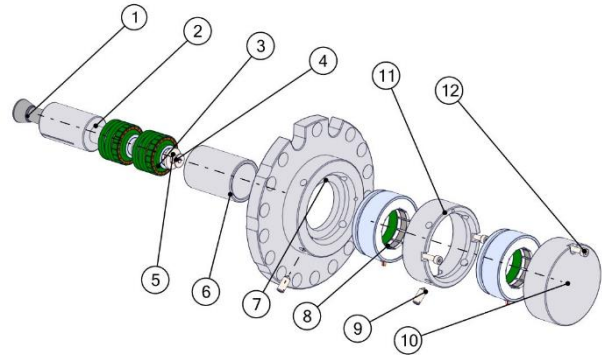

Figure 8: Required mounting parts

Description	Note	ID	Qty.
Tapered bolt	/	1	1
Rotor holder	/	2	1
Resolver rotor	/	3	2
Washer	/	4	1
M4x20 bolt	/	5	1
Adapter	268, 348 only	6	1
Resolver bracket	/	7	1
Resolver stator	/	8	2
DIN 914 set screw	/	9	8
Resolver cover	/	10	1
Tandem bracket	/	11	1
DIN912 M2.5x20	/	12	3

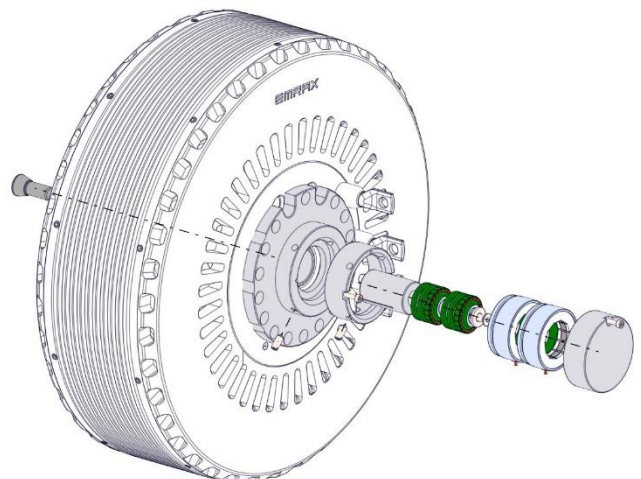

Figure 9: Twin resolver assembly

1. Place an adapter shaft (6) inside the motor shaft (this step is only required for the 268 and 348 motor types). Before inserting the part use threadlocker glue on the faces, where the parts are mated.
2. Assemble the two rotors of the resolver. Start by applying threadlocker glue on the mating surfaces of the resolver rotor (3) and rotor holder (2) and pressing the parts together. Then insert the tapered bolt (1) into the rotor holder (2) and lightly tighten it. Using threadlocker glue supplied with the kit on the threads is recommended. Continue by screwing the resolver rotor (3) onto the rotor holder (2) by using the washer (4) and bolt (5) supplied with the kit.

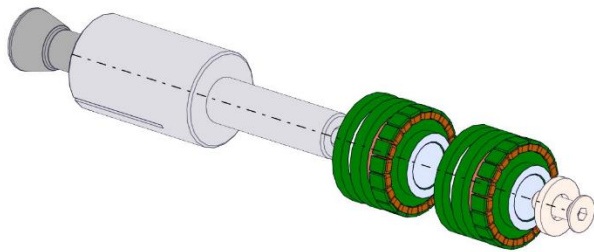

Figure 10: Rotor assembly

3. Insert the rotor assembly into the backside of the motor, inside the motor shaft (as shown on figure 9). Before inserting the part use threadlocker glue on the faces, where the parts are mated.
4. Mount the resolver bracket (7) on the back of the motor. Make sure that it is seated in its position, if necessary, use temporary bolts to tighten it to the motor. (If the motor is liquid or combined cooled, please make sure that the coolant fittings are inserted, before mounting the encoder bracket, please refer to 3.5).
5. Mount the first resolver stator (8) to the mounting flange of the resolver bracket (7). While holding the resolver stator (8) down, use DIN 914 set screws (12) to bolt it down from the side. Using threadlocker glue supplied with the kit on the threads is recommended.

6. Make sure that the resolver stator and rotor teeth of the first (bottom) resolver are aligned as on the picture bellow.

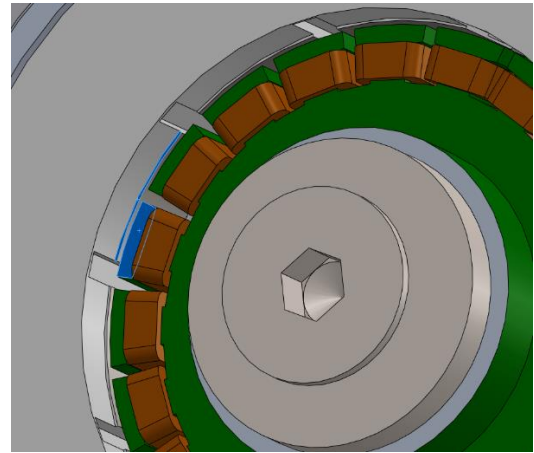

Figure 11: Tooth alignment

7. Tighten the tapered sensor bolt (13).
8. Mount the tandem bracket (11) to the first resolver stator (8). Bolt it down with the supplied DIN912 M2.5x20 bolts. Using threadlocker glue supplied with the kit on the threads is recommended.
9. Mount the second resolver stator (8) to the mounting flange of tandem bracket (11). While holding the resolver stator (8) down, use DIN 914 set screws (12) to bolt it down from the side. Using threadlocker glue supplied with the kit on the threads is recommended.
10. Mount the resolver cover (10) on the back of the resolver stator (8). Bolt it down with the supplied DIN912 M2.5x20 bolts. Using threadlocker glue supplied with the kit on the threads is recommended.

Bolt size	Recommended Torque [Nm]	
	Dry	Lubed
M2.5x0.45	1.5	1
M4x0.7	4	3
M6x1	16	13
M8x1.25	40	32

3. Motor installation

3.1. General space requirements

Electric machines should be installed to allow an easy access for inspection and maintenance. Should the surrounding atmosphere be humid, corrosive or contain flammable substances or particles, it is essential to ensure an adequate degree of protection. The installation of motors in environments where there are vapours, gases or dusts, flammable, or combustible materials, subject to fire or explosion, should be undertaken according to appropriate and governing codes, such as NEC Art. 500 (National Electrical Code) and UL-674 (Underwriters Laboratories, Inc.) Standards.



Under no circumstances can motors be enclosed in boxes or covered with materials which may impede or reduce the free circulation of ventilating air. Machines fitted with external ventilation should be at least 150 mm from the wall to permit the passage of air.

The opening for the entry and exit of air flow should never be obstructed or reduced by conductors, pipes, or other objects. The place of installation should allow for air renewal at a rate of **20 cubic meters** per minute for each 50 kw of motor capacity (please ensure that the ambient temperature of surrounding air remains stable during motor operation).

See cooling details for each motor cooling type under section 2.4. Motor cooling.

3.2. Mounting the motor

Motors should be mounted on firm flat base with 4 bolts (highlighted) via X bracket bought with the motor:

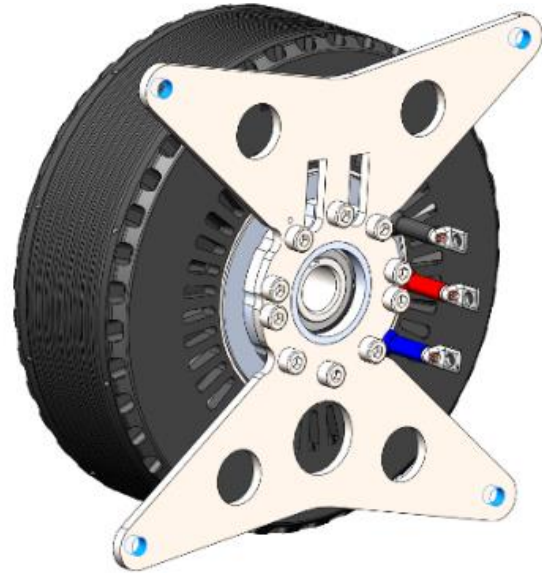

Figure 12: X bracket

If factory mounting bracket is not selected, the motor can be mounted from back side, through the back flange of the motor utilizing a stator-spacer supplied with the motor, or the positioning sensor bracket.

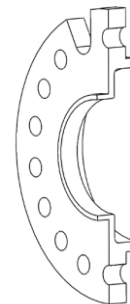

Figure 13: Stator spacer

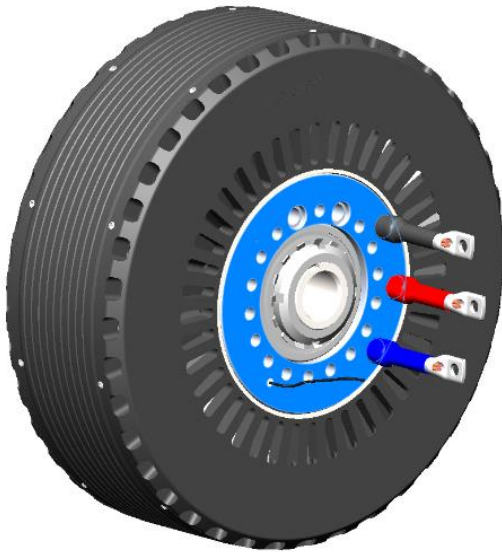



Figure 14: Highlighted mounting plate

When bolting the motor, take care to permit a minimum of $1.5 \times$ bolt diameter thread turns to protrude inside the flange. For example, a M6x1 bolt should have at least ($1.5 \times 6 =$) 9 turns protruding inside the motor, which in turn means that a minimum of (Pitch * Turns =) 9mm of bolt length should be locking the threads.

Using a thread-locking adhesive or securing the bolts with a safety wire/washer is advised.



A minimum of 6 bolts, evenly spaced around the flange should be used. The bolts must be of quality 8.8 or higher.

Use the bellow prescribed torques when bolting the motor:

Bolt size	Recommended Torque [Nm]	
	Dry	Lubed
M6x1	16	13
M8x1.25	40	32

3.3. Motor output

The motor is designed to output it's torque via the motor flange on the front of the motor.



Figure 15: Motor flange

Custom flange can be manufactured, or a flanged shaft (FSI) can be bought from EMRAX. Please find a table with appropriate bolts and required torque for tightening them under twin installation chapter.

If custom shaft is used, it should be designed to align with the inner bore of the motor flange. The tolerance of the shaft where in contact with the bore should be g6.



When bolting a custom shaft to the motor, make sure that the bolts are not protruding inside the motor. After installation, check for smoothness of rotation by hand turning the motor.

The electric motor should be accurately aligned with the driven machine. An incorrect alignment can cause bearing failure vibrations and even shaft rupture.

It is recommended to use a coupling between the motor and the driven shaft.

The best way to ensure correct alignment is to use dial gauges placed on each coupling half:

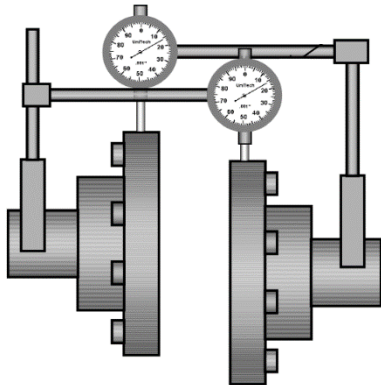

Figure 16: Alignment measurement

The space between coupling hubs should be maintained as recommended by the coupling manufacturer. Shaft offset should not exceed 0.03 mm. Angular misalignment should be less than that recommended by the coupling manufacturer.

Hammers should be avoided during the fitting of shaft flanges or pulleys to the motor. The fitting with the aid of hammers leaves blemishes on the bearing races. These initially small flaws increase with usage and can develop to a stage that completely impairs the bearing.

3.4. Twin motor assembly

EMRAX can supply parts necessary to combine two motors to form a twin motor configuration.

A twin motor configuration consists of two motors:

- Motor with extended shaft (ESO) (Front motor)
- Standard motor + addition of FSI shaft (Rear motor)

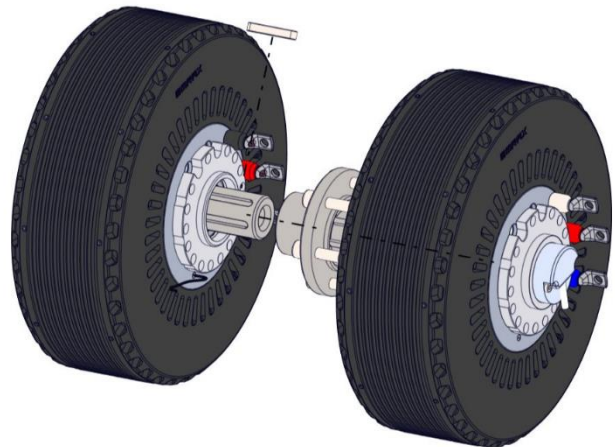

Figure 17: Twin assembly

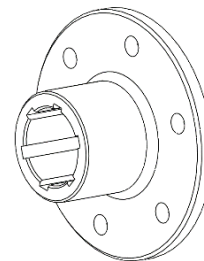

Figure 18: FSI shaft (Flanged Shaft Inner splines)

Mounting the motors together:

1. Mount the FSI shaft to flange of the rear motor
In the table below, you will find an appropriate length of the bolts for bolting the motors together with our FSI shaft. It is recommended to use locking washer and thread locking glue on the bolts. Using bolts of grade 8.8. or higher is required. After the FSI shaft is secured to the motor, check for smoothness of operation.

Motor size	Bolt size and length	Torque [Nm]	Qty.
188	M6x20	13	6
208	M8x25	32	6
228	M8x25	32	6
268	M8x30	32	6
348	M10x35	70	6

2. Insert keys into key slots on the ESO shaft on the front motor.

Motor size	Key used (DIN 6885)	Qty.
188	A4x4x32	4
208	A5x5x40	6
228	A5x5x40	6
268	A6x6x40	6
348	A6x6x50	6

3. Slide the two motors together. It is prohibited to use excessive force or hammer during this step.

Take note that it is only possible to use a positioning sensor on the rear motor. A single encoder with an encoder signal splitter device, that can then feed multiple ESC's, or a tandem resolver configuration can be used.

If twin configuration will be ordered from factory, it will come mounted as in the bellow picture:

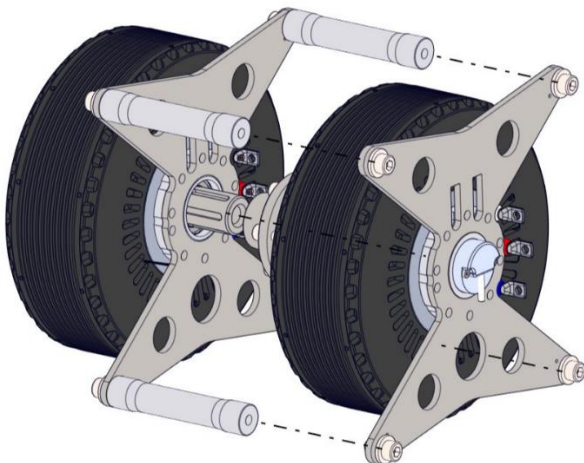



Figure 19: Twin assembly with accessories

The axial length of the motor will depend on your application. When the motors are slid together, please ensure 2-10mm of axial clearance from its end position.



Both motors must be secured (bolted) to the structure when using the twin configuration. Make sure that when bolting the two motors, you are not imposing any radial or axial force.

3.5. Motor cooling

In case of using liquid or combined cooled motor (LC/CC), coolant needs to be supplied to the motor at rates given in the bellow table, according to their designation:

Designation	Min. flow rate	Pressure drop (6 l/min)	Coolant volume (ml)
188	6 l/min	0.2 bar	80
208	6 l/min	0.5 bar	100
228	6 l/min	0.5 bar	100
268	6 l/min	0.5 bar	100
348	6 l/min	0.3 bar	140

Water inlet temperature should not exceed 50°C.

The stated power in datasheets is measured at inlet temperature prescribed there.

Please note that with higher inlet coolant temperatures, continuous motor power is reduced.



Maximum inlet pressure should not exceed 2 bar(g). No particles greater than 50 µm are permitted.

Water cooling channels are symmetrical in design, its input and output can be interchanged. It's important to deaerate the motor when connecting to coolant supply. The preferred way is using a vacuum on the outlet.

Demineralized water or glycol mixture are the preferred coolant options. Do not expose the motor directly to salt water, as internal damage may occur.

Rubber hose of inner diameter 10mm should be installed and secured with a clamp on the coolant fittings.



Under no circumstances can motors be enclosed in boxes or covered with materials which may impede or reduce the free circulation of ventilating air. Machines fitted with external ventilation should be at least 150 mm from the wall to permit the passage of air.

AC – air cooled motor is designed for aviation applications where there is a sustained velocity of air circulating the motor. **The parameters found in data sheet are measured at an air flow rate of 20 m/s with a temperature of 20 °C.**

The motors can be used in an ambient flow and temperature environment, however, expect the continuous duty cycle of the motors to be much lower. Please refer to EMRAX support on advice regarding your application.

CC (combined cooled) motor can be used as only a water-cooled motor (see above table for pressure drops and flow rates) or as a combined (see AC requirements). Please refer to LC motor data in case you are only using water cooling.

Please be advised that AC and CC motors are subject to (metal) particle ingress. Take caution when handling and transporting the motors.



Motor temperature shouldn't at any moment exceed 120°C, as recorded by motor temperature sensor.

It is advised that when firstly dealing the motor, the current derating point is set at 100°C.

3.6. Coolant fittings replacement

Coolant fittings are fitted in place and secured with an over flange covering the overlap.

Sealing is done with O-rings. The standard O-rings are VMQ70 9x1.5.

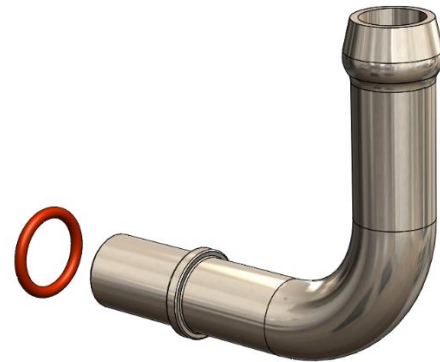

Figure 20: Required mounting parts

To install the fittings to the motor:

1. Grease and install the O-ring onto the coolant fitting
2. Press the fitting into the cooling channels of the motor, while gently rotating it from side to side

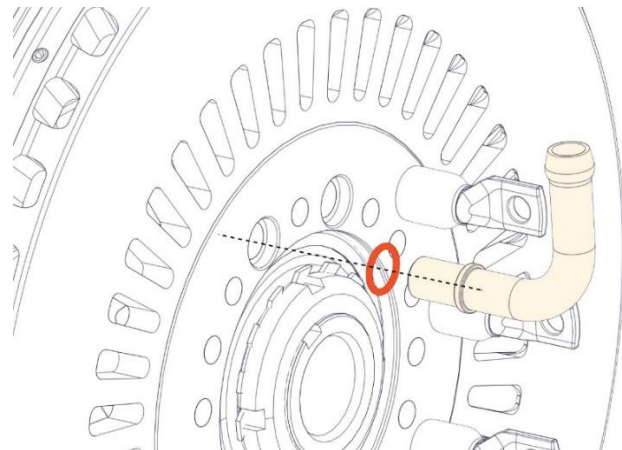

Figure 21: O-ring mounting

3.7. Temperature and sensor connection

The default temperature sensor built into the motor is type KTY 81-210. The wires coming out of the motor are naked with a cross-section of 0.75mm². The wires can be orientated either way.

There are several selections on motor position sensor depending on your motor controller choice. Please turn to their respectful manufacturers to get the required info on wiring, shielding and colour codes.

3.8. Power supply and connections

Turn to motor manual according to motor nameplate, to find suitable data on the voltage and current required by the electric drive.

The power cables must comply with established practice and standards and be properly insulated and rated for the current draw; the connection cabling and cable cross sections must comply with EN 60204.



When dealing with electrical connections, ensure that the system is not under voltage.

The use of electro-insulating gloves is recommended, when dealing with high voltage electrical connections.

Using an IMD (insulation monitoring device), when using voltages higher than 48V is advisable.

Check that the motor's wires are properly tightened down to the cable shoes with positive locking (DIN 980, locking washers or similar).

Ensure insulation on motor connections by using heat shrinks or similar. For watertight connection we recommend using adhesive lined heat shrink tubing.

Motor mounting point should be shielded to the main ground of the system.

Power cables must be supported at a maximum distance of 200 mm from the connection. Resting the weight of the cable on the motor connections can result in their dynamic failure.



Figure 22: Cable support example

4. Steps prior to starting

4.1. Steps prior to starting



WARNING:
If the motor has been in a damp location, dry it out thoroughly before operating. Before energizing the motor for the first time or after an extended shut down, it is advisable to check the insulation resistance, power supply and mechanical freedom of the motor.

4.2. Initial start



WARNING:
Do not touch or reach into moving parts, while the motor is operating!

Whenever possible, examine the interior of the motor for loose objects or debris which may have accumulated and remove any foreign material.

If possible, turn the rotor by hand to be sure, that it rotates freely.

Check all connections with the connection diagram. Check all accessible factory made connections for tightness to make sure none has become loose during shipment.

When the driven load is likely to be damaged by the wrong direction of rotation, it is best to uncouple the motor from its load during the initial start and make certain it rotates in the correct direction.

After inspecting the motor carefully, make the initial start by following the regular sequence of starting operations as prescribed by motor controller manufacturer.

In the event of excessive vibration or unusual noise disconnects the motor from the load and check the mounting and alignment. If the issue is not resolved, please contact EMRAX support for further instructions.

5. Maintenance

5.1. General

When the motor is in operation, examine the motor at regular intervals depending on the service. Check the following items:

- Make sure the ventilation openings are clear and unobstructed.
- General cleanliness.
- Check the condition of shaft seals and replace if necessary.
- Check the condition of connections and mounting and assembly bolts.
- Check the bearing condition by listening for any unusual noise, vibration measurement, bearing temperature, inspection of spent grease or SPM bearing monitoring.

5.2. General cleanliness

Motors should be kept clean, free of dust, debris, and oil. Soft brushes or clean cotton rags should be used for cleaning. A jet of compressed air should be used to remove non-abrasive dust and any accumulated grime. Oil or damp impregnated impurities can be removed with rags soaked in a suitable solvent.

5.3. Vacuum and compressed air cleaning

Compressed air or suction should be used to remove loose dirt and dust from air and coolant passages.



Care must be taken to make sure the air is dry and that the pressure of not more than 2 bar(g) is used.

5.4. Cleaning with water and detergent

Water-solvent mixture is a very effective way in cleaning coolant channels against accumulated dirt.



Care must be taken to make sure that the pressure of not more than 2 bar(g) is used, and that the temperature never exceeds 90 °C.

5.5. Bearings

Bearings are assembled and pretensioned in factory and are greased for its entire life cycle. Their appropriate life cycle is to be determined by a customer using their boundary conditions. In case of bearing failure, please contact EMRAX representative or contact EMRAX support directly for inspection or possible replacement.

5.6. Failure



WARNING: An extreme overload or electrical failure may result in heating or arcing which can cause the insulation to give off noxious fumes. All power should be removed from the motor circuit as a precaution even though the circuit has overload protection. Personnel should not approach the motor until adequate ventilation of the area has purged the air of fumes. When covers of a motor are removed after a failure, care should be observed to avoid breathing fumes from inside the motor. Preferably, time should be allowed for the motor to cool before attempting any examination.



WARNING: Water should not be applied to any electrically energized equipment because electric shock could result in serious or fatal injury. In case of fire, disconnect all power and use a carbon dioxide extinguisher to quench the flame. Before operating any motor after a suspected failure, it should be inspected for damage.

5.7. Repair

If suspecting motor failure, please contact EMRAX representative or contact EMRAX support directly for further instructions regarding the motor repair. The following must be sent to EMRAX to process a motor repair:

- Original nameplate from the failed motor.
- Copy of the original invoice or invoice # for the failed motor.
- Brief description of the failure for quality control purposes.

- Please send request no later than 30 days after failure.

Any unauthorized attempts in disassembling the motor will result in warranty void, and further damage to the motor may occur.

5.8. Warranty

EMRAX provides a limited warranty on our products against defects in materials and workmanship for a period of twelve (12) months, from the date of delivery.

During the warranty period, EMRAX will repair or replace, at no charge, products or parts of a product that proves defective because of improper material or workmanship, under normal use and maintenance. Repaired or replaced product will have a warranty extended for a period of twelve (12) months from the date of delivery.

The warranty shall be void and of no effect if the following are performed & found on the motor:

- (1) The motor has been subjected to improper installation, storage, or handling; as well as any abuse unsuitable for the motor;
- (2) The motor was subjected to an unauthorized repair.
- (3) The motor was subject to any water damage;
- (4) The motor was engaged above its rated load;
- (5) The motor lacked reasonable & necessary maintenance.
- (6) The motor usage was not according to its installation manual
- (7) Improper packaging for return.

EMRAX does not cover the cost of installation, removal, or re-testing of the new or repaired products.

EMRAX will not be liable for any costs or damage incurred by its customers in the removal or replacement of defective products from units in which the products have been assembled. When processing a warranty claim, please contact

EMRAX support and provide the following:

- Original nameplate from the failed motor.
- Copy of the original invoice or invoice # for the failed motor.
- Brief description of the warranty claim.
- Please send request no later than 30 days after failure.

Document Revision history:

<u>Revision</u>	<u>Date</u>	<u>Author</u>	<u>Description</u>
1.0	06/12/2021	U.K.	Initial version
1.1	22/12/2021	U.K.	Revised nameplate and motor cooling
1.2	21/02/2022	U.K.	Updated pressure drop values
1.3	09/03/2022	U.K.	Added warranty claim, revised 2.6 and 2.4
1.4	19/10/2022	U.K.	Revised manual, added installation instructions
1.5	16/08/2023	U.K.	Added mounting instructions for tandem res.